

# STRAINER FOR FLANGE

## CA 3241 CREPINOX

Ref.:CA3241CREPINOX

Rev. : Initial

Date : 22/10/2013



PA Ventiler AB

GO WITH OUR FLOW

### APPLICATION

General use : for water distribution and draining.

### GENERAL CHARACTERISTICS

From DN50 to DN300.  
For flange connection.  
Mesh 6 mm  
With bolting.

### DIMENSIONS

DN		H	ØA	ØK	ØD	n x ØM	f	Weight (kg)
mm	inch							
50	2"	77	91	125	158	4 x Ø9	2,5	0,426
65	2 1/2"	100	127	145	180	4 x Ø9	2,5	0,746
80	3"	125	127	160	180	4 x Ø9	2,5	0,858
100	4"	142	164	183	212	4 x Ø9	2,5	1,096
125	5"	166	180	210	240	4 x Ø9	2,5	1,432
150	6"	200	212	240	268	4 x Ø9	2,5	1,796
200	8"	300	255	285	318	4 x Ø9	2,5	2,527
250	10"	380	330	362	395	4 x Ø9	2,5	4,500
300	12"	410	380	415	445	4 x Ø9	2,5	5,386

### WORKING CONDITIONS

Maximum working conditions : -20°C / +200°C

Maximum working pressure: 16 bar

### STANDARDS

Fabrication according to ISO 9001 :2000  
Flanged connection: ISO PN10/16 from DN50 to DN150  
ISO PN16 from DN200 to DN300..

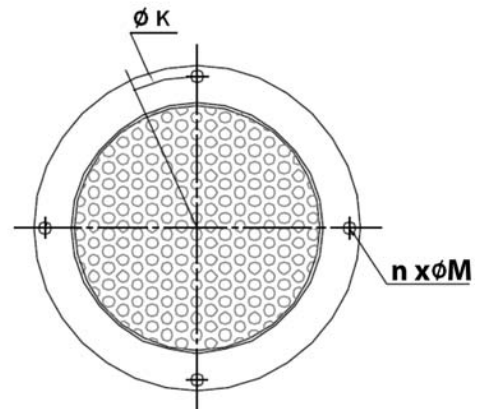
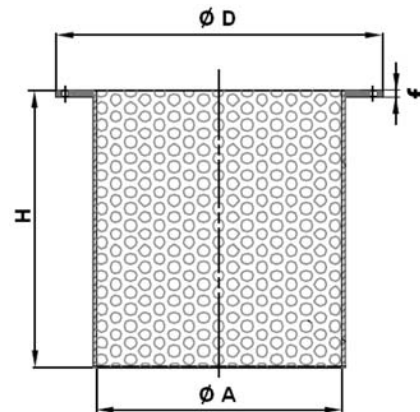

The photographs and technical art works are not contractual. The specifications of the presented products are open to modifications without previous advice.

