

# FLANGED TYPE "Y" STRAINER PN 16 WITH MAGNETIC COLLECTOR

## F 3240NA / F 4240NA

Ref. : F 3240NA  
F 4240NA

Rev. : A

Date : 22/08/2016



PA Ventil AB

GO WITH OUR FLOW

### APPLICATION

Heating system and undrinkable domestic water, steam and other compatible fluids.

### GENERAL CHARACTERISTICS

Filter equipped with a magnetic shaft for sensing the metal particles contained in the fluid. "Y" body and bonnet in cast iron from DN15 to DN300 (F 3240NA) and in ductile iron for DN350 and DN450 (F 4240NA). Epoxy coating RAL 5019 with thickness 80-100µm. Dismountable stainless steel screen. Drain plug G3/8 (DN15-20); G1/2 (DN25-100); G3/4 (DN125-400) Flanged ends PN 16.

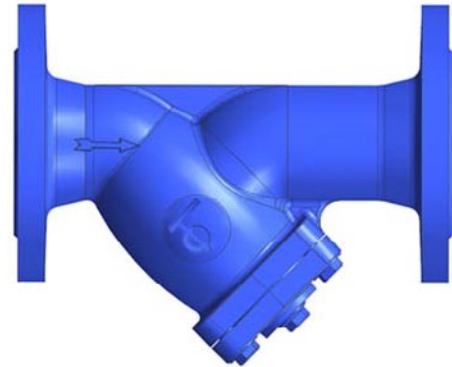

### CONSTRUCTION

9	3	Magnet		
8	1	Shaft	Stainless steel 304	
7	1	Drain plug	Acier A 105	
6	1	Gasket	Graphit	
5	**	Screw	Steel A 105	
4	1	Bonnet	Cast iron EN-GJL-250 (DN15-300)	
			Ductile iron EN-GJS-400-15 (DN350-400)	
3	1	Gasket	Graphit	
2	1	Screen	Stainless steel	DIN: X5CrNi18 10
			X5CrNi 18-10	ASTM: A 182 AISI 304 BS: 1449-2 304 S15
1	1	Body	Cast iron EN-GJL-250 (DN15-300)	
			Ductile iron EN-GJS-400-15 (DN350-400)	
<b>Pos.</b>	<b>Q-ty</b>	<b>Description</b>	<b>Material</b>	

\*\* 4 for DN15-100 and 6 for DN125-400

### DIMENSIONS

DN	L	ØD	ØD1	ØD2	b	z	Ød	H	HI	Weight (kg)	Mesh (mm)
15	130	95	65	45	16	4	14	74	110	3	1
20	150	105	75	58	16	4	14	90	130	3.2	
25	160	115	85	68	16	4	14	95	160	4	
32	180	140	100	78	16	4	18	119	171	6	
40	200	150	110	88	18	4	18	130	195	7	
50	230	165	125	102	20	4	18	145	218	8	
65	290	185	145	122	20	4	18	160	248	12	
80	310	200	160	138	20	8	18	185	283	14	
100	350	220	180	158	22	8	18	225	351	18	
125	400	250	210	188	26	8	18	268	418	32	
150	480	285	240	212	26	8	23	295	468	45	
200	600	340	295	268	30	12	23	316	529	80	
250	730	405	355	320	32	12	23	420	662	130	
300	850	460	410	378	36	12	27	455	735	170	
350	980	520	470	438	30,5	16	27	565	915	240	
400	1100	580	525	490	32	16	30	635	1041	345	

### WORKING CONDITIONS

Maximum working pressure : 16 bar .  
Maximum temperature: 130°C

Pressure test according to standards  
EN 12266-1, DIN 3230, BS 5154 and ISO 5208 :  
Body : 24 bar.

### STANDARDS

Face to face according to standards EN 558-1  
serie 1 and DIN 3202/1 serie F1.  
Flanges drilled according to EN 1092-2 PN16.

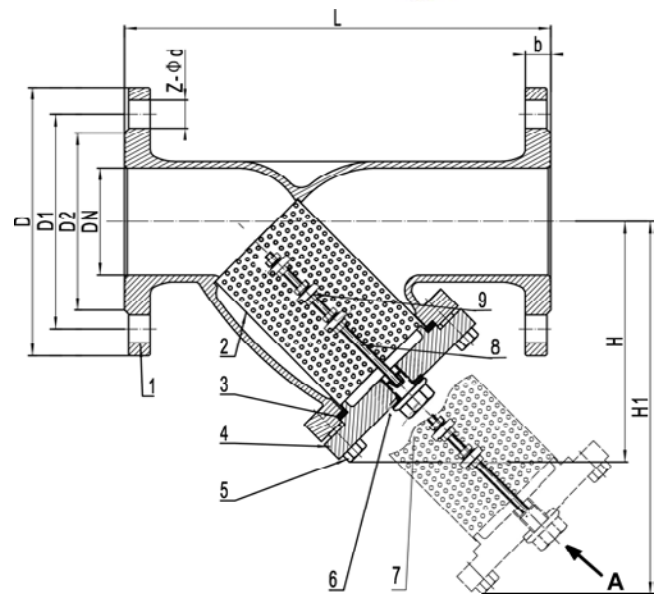

VIEW A

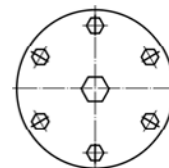

DN 125 - DN 400

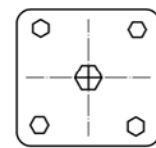

DN 15 - DN 100

