

H TYPE STRAINER PN 16

F 4240

Ref. : F 4240

Rev. : Initial

Date : 24/10/2013



PA Ventiler AB

GO WITH OUR FLOW

APPLICATION

Pumping and water distribution.

GENERAL CHARACTERISTICS

Compact and robust design.
Ductile iron body and bonnet.
Food epoxy coating.
Curved stainless steel strainer.
Standard mesh: 2 x 2 mm.
Drain plug (1 1/4 ").
Flanged PN16.

CONSTRUCTION

5	4	Bolt	Stainless steel
4	1	Drain plug	Stainless steel
3	1	Bonnet	Ductile iron GGG40
2	1	Strainer	Stainless steel
1	1	Body	Ductile iron GGG40
Pos.	Q-ty	Description	Material

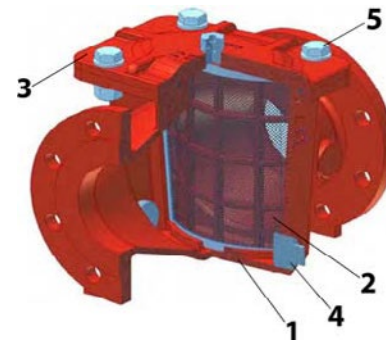

DIMENSIONS

DN		A	B	C	D	R	Mesh (mm)	Weight (kg)
mm	inch							
80	3"	300	103	15	235	1"1/4	2x2	22
100	4"	300	150	150	235	1"1/4	2x2	23
125	5"	400	125	191	400	1"1/4	2x2	46
150	6"	400	142.5	191	400	1"1/4	2x2	48
200	8"	500	70	224	460	1"1/4	2x2	76
250	10"	580	225	295	560	1"1/4	2x2	165
300	12"	610	227.5	385	680	2"	2x2	230
350	14"	650	227.5	380	680	2"	2x2	250
400	16"	800	310	500	900	2"	2x2	410
450	18"	800	335	500	900	2"	2x2	430
500	20"	950	485	609	1190	3"	2x2	770
600	24"	1100	485	609	1190	3"	2x2	850

WORKING CONDITIONS

Maximum working pressure : 16 bar

STANDARDS

Pressure test according to EN 12266-1,
DIN 3230, BS 5154 and ISO 5208 :
Body : 24 bar.
Flanges according to EN1092-2 ISO PN16.

