

# PN 16 FLANGED TYPE SENSORS WITH CONVERTER MC 608 A MUT 2200 ELPN 16

Ref. : MUT2200ELPN16

Rev. : A

Date : 19/10/2016



PA Ventil AB

GO WITH OUR FLOW

## APPLICATION

These sensors are typically used in the measure of potable or recycled water, industrial waste water, industrial process liquids, mud and concretes.

## GENERAL CHARACTERISTICS

Range from DN15 to DN400.  
Coupled version with converter MC608 A with LED. 4 standard electrodes in hastelloy C guarantee a wide compatibility with different kind of liquids.  
By request they may be supplied in hastelloy B, Titanium, Tantalum or Platinum.  
Measurement range of more than 1:1000 without linearization software.  
Accurate measures on a wide flow rate range and a lower flow rates.  
Carbon steel flange and sensor with acrylic painted external surface.  
(Flange and sensor in stainless steel 304 or 316 on request)  
PTFE internal lining material on standard from DN15 to DN100 and over by request. Protection IP67. Voltage: 80-265 VAC, output 4-20mA + 485 MODBUS interface ICOM.

## DIMENSIONS

DN		ØD5	L4	J	Di	D6	N	ØS	H	H1
mm	inch									
15	1/2"	84	200	112.2	11.3	65	4	14	-	-
20	3/4"	84	200	112.2	16.9	75	4	14	-	-
25	1"	74	200	107.2	23.7	85	4	14	37	220
32	1 1/4"	83	200	111.7	31.8	100	4	18	42	225
40	1 1/2"	88	200	114.2	37.3	110	4	18	44	227
50	2"	102	200	121.2	47.3	125	4	18	51	234
65	2 1/2"	114	200	127.2	63.1	145	4	18	57	240
80	3"	127	200	133.7	74.3	160	4	18	64	247
100	4"	161	250	150.7	97	180	8	18	81	264
125	5"	187	250	163.7	122	210	8	18	94	277
150	6"	210	300	175.2	148	240	8	22	105	288
200	8"	261	350	200.7	195	295	12	22	131	314
250	10"	319	450	229.7	245	350	12	25	160	343
300	12"	371	500	255.7	308	400	12	25	186	369
350	14"	404	550	272.2	339.6	470	16	25	202	385
400	16"	455	600	297.7	390.4	525	16	30	228	411

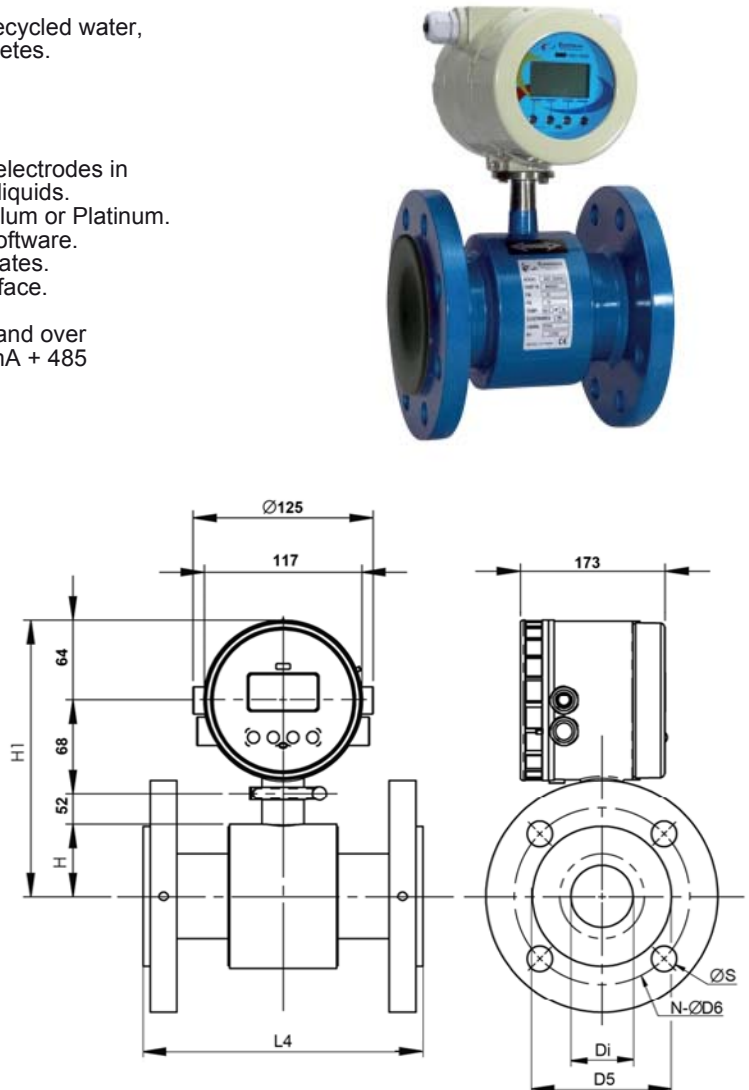

## WORKING CONDITIONS

Working pressure : 16 bar.  
Maximum temperature : 0°C / + 70°C

## FLOW RATE

DN		Flow (m3/h)				
mm	inch	Q1 (minimum)	Q2 (transitional)	Q3 (permanent)	Q4 (overload)	Ratio Q3/Q1
15	1/2"	-	-	-	-	-
20	3/4"	-	-	-	-	-
25	1"	0,08	0,128	10	12,5	12,5
32	1 1/4"	0,08	0,128	10	12,5	12,5
40	1 1/2"	0,128	0,205	16	20	12,5
50	2"	0,2	0,32	25	31,25	12,5
65	2 1/2"	0,32	0,512	40	50	12,5
80	3"	0,504	0,806	63	78,75	12,5
100	4"	0,8	1,28	100	125	12,5
125	5"	1,28	2,048	160	200	12,5
150	6"	2	3,2	250	312,5	12,5
200	8"	3,2	5,12	400	500	12,5
250	10"	5,04	8,064	630	787,5	12,5
300	12"	8	12,8	1000	1250	12,5
350	14"	12,8	20,48	1600	2000	12,5
400	16"	12,8	20,48	1600	2000	12,5

## STANDARDS

Flange connection ISO PN 16 according to EN 1092-1, ISO 7005-1.



The photographs and technical art works are not contractual. The specifications of the presented products are open to modifications without previous advice.