

DOUBLE EXCENTRIC TYPE BUTTERFLY VALVE WITH ELECTRIC ACTUATOR BERNARD VP 4251-B04

Ref. : VP 4251-B04.pas

Rev. : Initial

Date : 02/09/2016



PA Ventil AB

GO WITH OUR FLOW

APPLICATION

General use : potable water.

GENERAL CHARACTERISTICS

TECWAT type : long pattern.
 Design in according to EN 593.
 Range : from DN 150 to DN 1600.
 Assembling with preferential sense
 Bi-directional on demand.
 Double excentric type.
 Replaceable seat, no wrenkling possibility.
 Food epoxy painting.

CONSTRUCTION

11	1	Electric actuator		BERNARD
10	2	Key	Stainless steel X20Cr13	DIN: 1.4021 ASTM: AISI 420 BS: 420 S 37
9	2	O-ring	EPDM	
8	1	Sealing ring	EPDM	
7	1	Cover free end	Ductile iron EN-GJS-500-7	DIN: GGG 50 ASTM: A536 70-50-05 BS: 1563 EN-JS1050
6	2	Bearing bush	Al-Bronze	
5	1	Shaft free end	Stainless steel X20Cr13	DIN: 1.4021 ASTM: AISI 420 BS: 420 S 37
4	1	Shaft driven end	Stainless steel X20Cr13	DIN: 1.4021 ASTM: AISI 420 BS: 420 S 37
3	1	Retaining ring	Steel	
2	1	Disc	Ductile iron EN-GJS-500-7	DIN: GGG 50 ASTM: A536 70-50-05 BS: 1563 EN-JS1050
1	1	Body	Ductile iron EN-GJS-500-7	DIN: GGG 50 ASTM: A536 70-50-05 BS: 1563 EN-JS1050
Rep.	Nb.	Designation	Material	

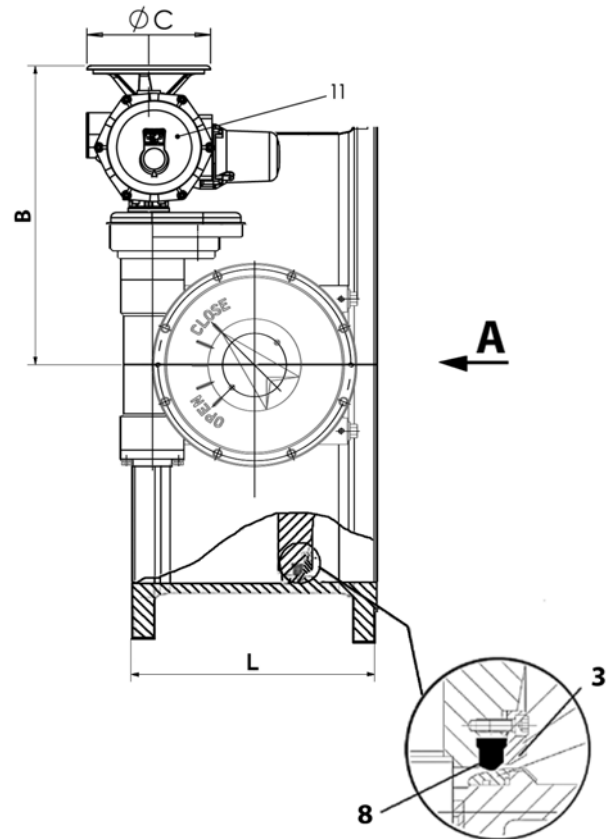

VIEW A

DIMENSIONS

DN		L	A	B	ØC	D	ØK	E	n-d	Actuator type	Weight (kg)
mm	inch										
150	6"	210	165	449	300	188	250	264	8-Ø28	ASM6	86
200	8"	230	190	490	400	221	310	300	12-Ø28	ASM10	113
250	10"	250	220	490	300	254	370	337	12-Ø31	ASM16	146
300	12"	270	250	504	400	298	430	377	16-Ø31	ASM10	219
350	14"	290	285	629	300	318	490	430	16-Ø34	ASM6	238
400	16"	310	315	627	400	370	550	486	16-Ø37	ASM10	377
450	18"	330	340	627	400	406	600	496	20-Ø37	ASM10	448
500	20"	350	370	658	400	453	660	554	20-Ø37	ASM10	595
600	24"	390	427.5	658	300	495	770	631	20-Ø41	ASM16	751
700	28"	430	485	702	400	601	875	715	24-Ø44	ASM10	1159
800	32"	470	547.5	702	300	668	990	797	24-Ø50	ASM16	1421
900	36"	510	597.5	763	400	695	1090	849	28-Ø50	ST14	2149
1000	40"	550	665	819	300	844	1210	988	28-Ø57 / 4-M52	ST14	2627
1200	48"	630	770	911	300	1008	1420	1179	32-Ø57	ST14	4067
1400	56"	710	882.5	963	450	1150	1640	1306	36-Ø62	ST30	5591
1600	64"	790	992.5	1141	450	1250	1860	1449	36-Ø62 / 4-M56	ST30	8399

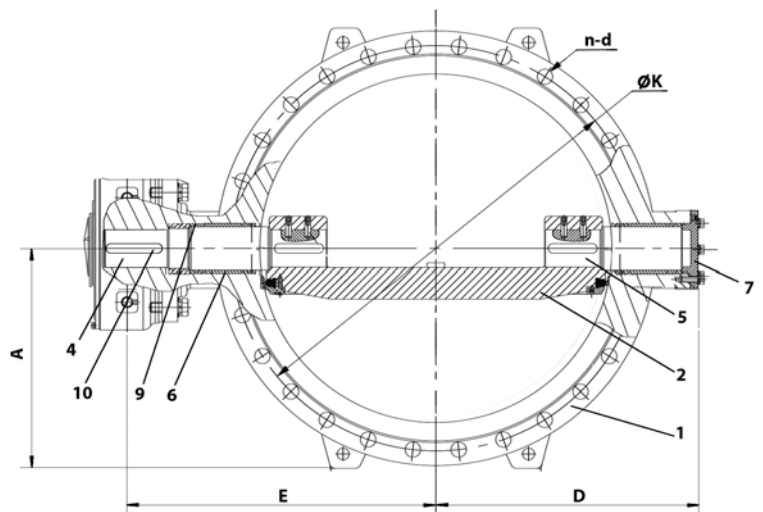

WORKING CONDITIONS

Maximum working pressure : 25 bar.
 Maximum temperature : + 80 °C.

STANDARDS

Design according to EN 593.
 Test procedures are established according to standards EN 12266-1 and API 598.
 Face to face according to standard EN 558-1 serie 14.
 Connections according to standard EN 1092-2 ISO PN25.
 Optional certificat of health conformity (ACS) by request.

