

DOUBLE EXCENTRIC TYPE BUTTERFLY VALVE WITH GEAR BOX TECWAT

VP 4261-08

Ref. : VP 4261-08.pas

Rev. : Initial

Date : 25/04/2014



PA Ventil AB

GO WITH OUR FLOW

APPLICATION

General use : potable water.

GENERAL CHARACTERISTICS

TECWAT type : long pattern.
 Design in according to EN 593.
 Range : from DN 200 to DN 1200.
 Assembling with preferential sense
 Bi-directional on demand.
 Double excentric type.
 Replaceable seat, no wrenkling possibility.
 Food epoxy painting.

CONSTRUCTION

11	1	Gearbox		
10	2	Key	Stainless steel X20Cr13	DIN: 1.4021 ASTM: AISI 420 BS: 420 S 37
9	2	O-ring	EPDM	
8	1	Sealing ring	EPDM	
7	1	Cover free end	Steel	
6	2	Bearing bush	Al-Bronze	
5	1	Shaft free end	Stainless steel X20Cr13	DIN: 1.4021 ASTM: AISI 420 BS: 420 S 37
4	1	Shaft driven end	Stainless steel X20Cr13	DIN: 1.4021 ASTM: AISI 420 BS: 420 S 37
3	1	Retaining ring	Steel	
2	1	Disc	Ductile iron EN-GJS-400-15	DIN: GGG 40 ASTM: A536 65-45-12 BS: 1563 EN-JS1030
1	1	Body	Ductile iron EN-GJS-400-15	DIN: GGG 40 ASTM: A536 65-45-12 BS: 1563 EN-JS1030
Rep.	Nb.	Designation	Material	

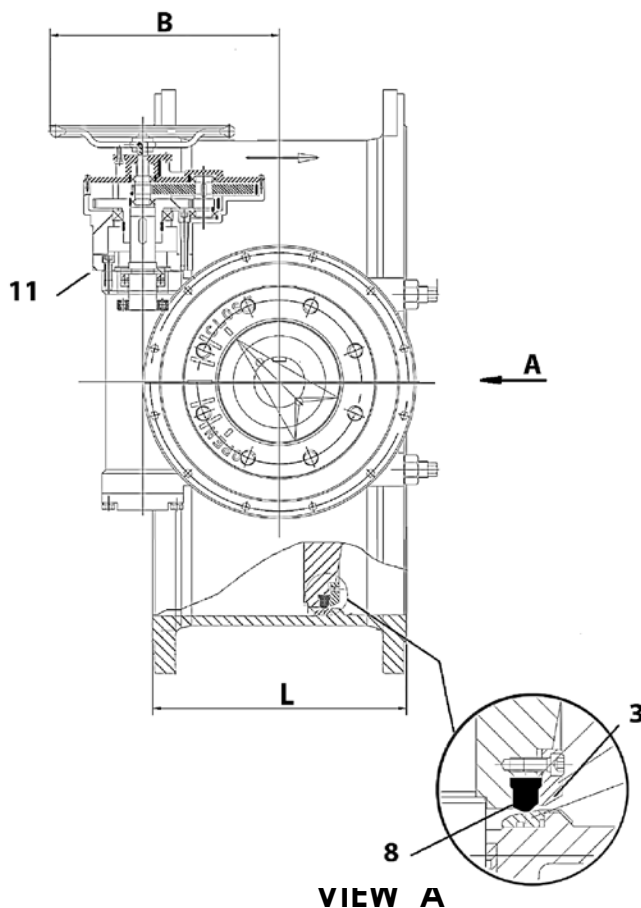

DIMENSIONS

DN		L	A	B	ØC	D	ØD1	ØD2	E	n-d	Weight (kg)
mm	inch										
200	8"	230	192.5	253.4	320	229	375	320	374	12-Ø31	90
250	10"	250	230	320	400	261	450	385	451	8-Ø34 / 4-M30	158
300	12"	270	262.5	320	400	305	515	450	490	12-Ø34 / 4-M30	265
350	14"	290	295	348	400	360	580	510	544	13-Ø37 / 4-M33	335
400	16"	310	335	348	400	407	660	585	594	12-Ø41 / 4-M36	405
450	18"	330	347.5	385	400	429	685	610	638	16-Ø41 / 4-M36	537
500	20"	350	382.5	385	400	477	755	670	703	16-Ø44 / 4-M39	777
600	24"	390	450	430	400	555	890	795	808	16-Ø50 / 4-M45	1069
700	28"	430	505	515	400	666	995	900	959	20-Ø48 / 4-M45	1650
800	32"	470	575	515	400	664	1140	1030	1032	20-Ø56 / 4-M52	2070
900	36"	510	635	515	400	785	1250	1140	1119	24-Ø56 / 4-M52	3020
1000	40"	550	690	612	400	837	1360	1250	1202	24-Ø56 / 4-M52	3705
1200	48"	630	792.5	795	600	1077	1575	1460	1518	24-Ø62 / 4-M56	5790

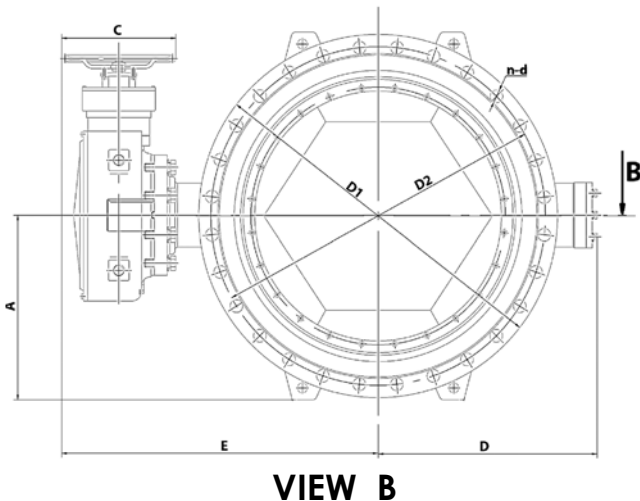

WORKING CONDITIONS

Maximum working pressure : 40 bar.
 Maximum temperature : + 80 °C.

STANDARDS

Design according to EN 593.
 Test procedures are established according to standards EN 12266-1 and API 598.
 Face to face according to standard EN 558-1 serie 14.
 Connections according to standard EN 1092-2 ISO PN40.

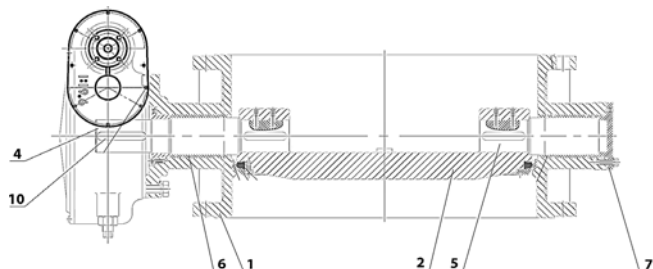

The photographs and technical art works are not contractual. The specifications of the presented products are open to modifications without previous advice.