

Mechanical Engineering

Reject Drums

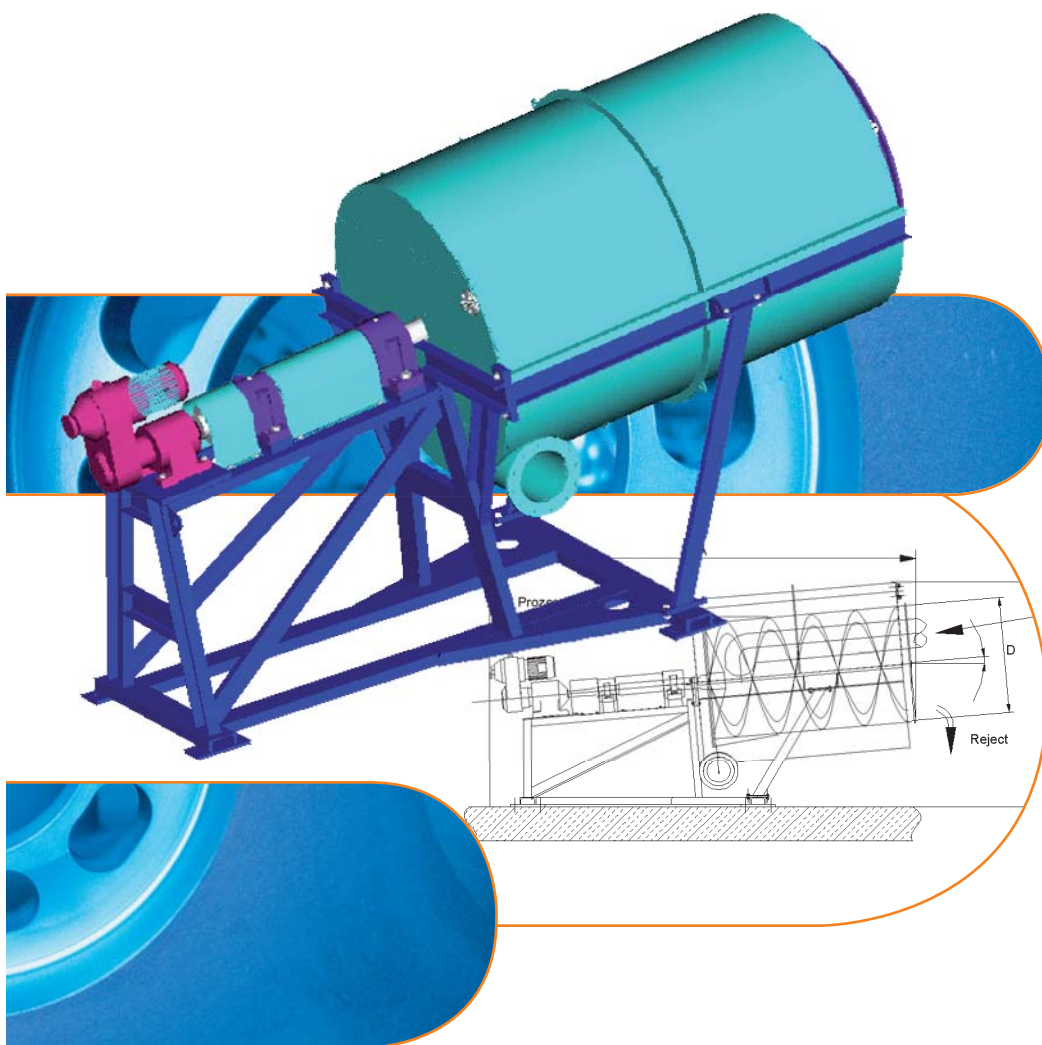

Maschinenbau Lohse GmbH
Unteres Paradies 63 · 89522 Heidenheim
Postfach 1565 · 89505 Heidenheim
phone +49(0)7321 / 755-79 · fax +49(0)7321 / 755-93
server.mb@lohse-gmbh.de ·
www.lohse-gmbh.de

Application

The reject drums remove medium and coarse dirt and foreign bodies of all kinds from pumping suspension. They are available in different sizes and with different sizes and types of holes, depending on throughput and application.

Construction

- drum sieve at a slight angle, fixed on one side
- adjustable belt drive adapts rotational speed to the individual application
- free-standing
- container for desired material under sieve
- spray tube
- built-in parts inside rotating sieve for mixing and transportation of reject material

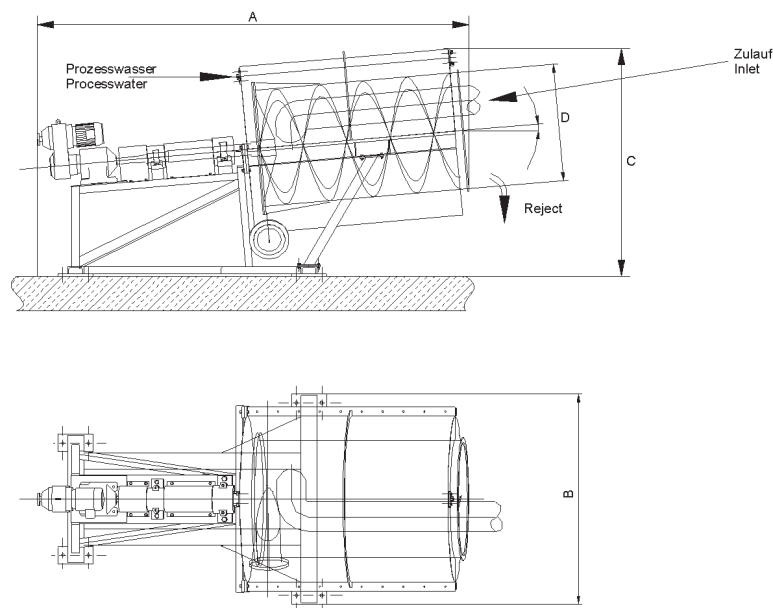

Technical data

size		02	03	04	09	014	022
open area	[m ²]	2,5	3	4,5	9	14,5	22
hole size	[mm]	16	16	16	16	16	16
consistency inlet approx.	[%]	2	2	2	2	2	2
production (varios depending plate dimension pulper, quality waste paper and defibring efficiency pulper)	[l/min]	720	900	1500	3480	5820	9000
length max. A	[mm]	2900	3000	3600	4400	5200	6100
width max. B	[mm]	1800	1800	1800	2000	2600	3000
height max. C (frame of drum can be adjusted to varios height)	[mm]	1880	1900	1950	2500	3000	3500
sieve diameter D	[mm]	800	800	1000	1250	1600	2000
sieve lenth L	[mm]	1000	1250	1600	2300	2800	3500
drumlength over all	[mm]			1750	2500	3210	
weigth unloaded	[kg]	1000	1200	1350	2950	3750	5400
spraypipes (installation of 2 spraypipes possible – add. price)	numb.	1	1	1	1	1	1
drive motor	[kW]	2,2	2,2	2,2	5,5	5,5	11
drum speed	[1/min]	4,3 ... 26 free adjustable					